

Installation of DAMPA 10/100/200/300

Modular Carrier No. 40 supports all types of ceiling units. The carriers are suspended by adjustment clips and perforated hangers. After fixing of the perimeter trims, the modular carriers are suspended. When using either edge trims or angle runners, a slot is cut at the ends of the modular carriers to splice into the upper flange of the edge trim or the horizontal flange of the angle runner. The first and last ceiling units should ideally be greater than half their module width. When using angle runners or open edge details, a leading edge return unit should be ordered as the first ceiling or it can be formed on site.

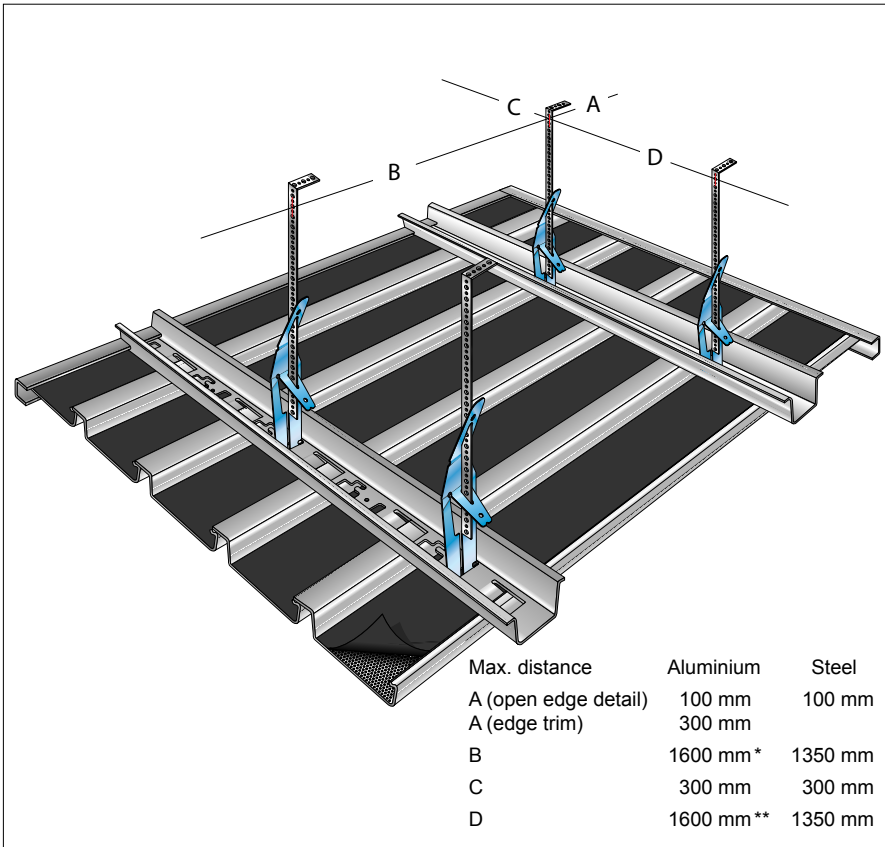

in the UK reduced to: * - 1350 mm, ** - 1500 mm

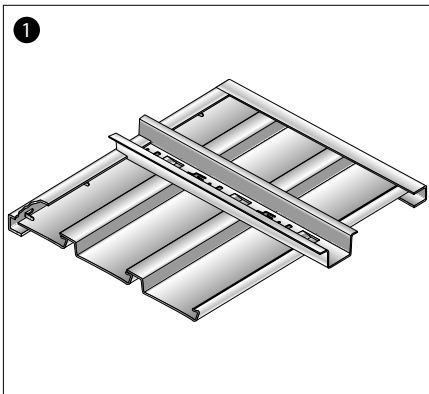

1 Edge Trim Type 1 is used at right angles to the ceiling units and Edge Trim Type 2 parallel to support cut units. Edge trims are fastened to the wall at intervals of maximum 500 mm.

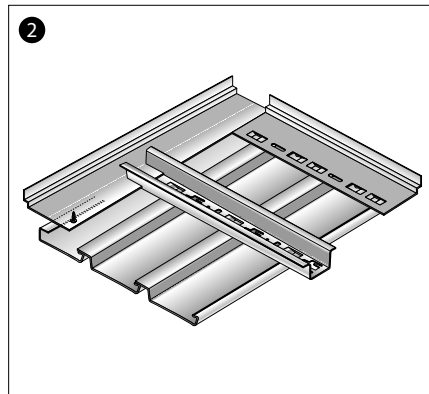

2 Angle Runner No. 1 with clips is used at right angles to the units (maximum distance to the first modular carrier 1600 mm) and Angle Runner No. 2 is used parallel to the units. The narrow flange of the leading edge return unit is supported by panhead self tapping screws fixed into the angle runners at max. 1600 mm centres. The angle runners are fastened to the wall at 500 mm intervals maximum.

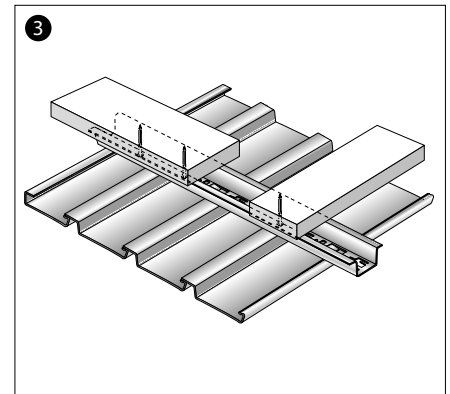

3 To prevent movement of the ceiling, modular carriers are braced against the wall with timber battens as shown. The first and the last modular carrier should be braced at right angles approx. every 2000 mm. Align all the carrier clips accurately. The wide flange of the first ceiling unit should not be visible. Order a leading edge return unit from DAMPA..

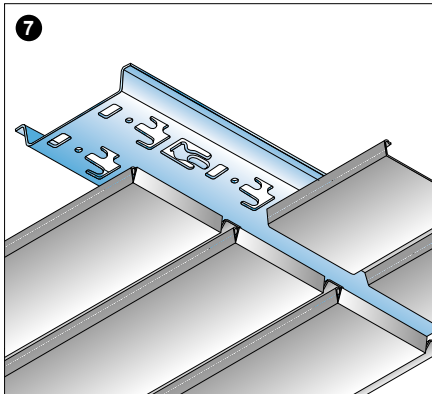
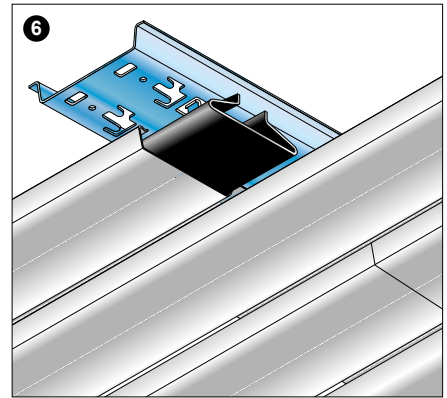
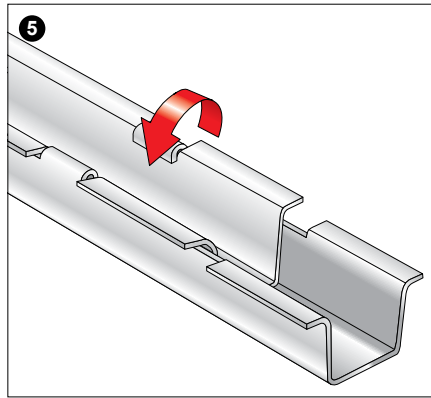
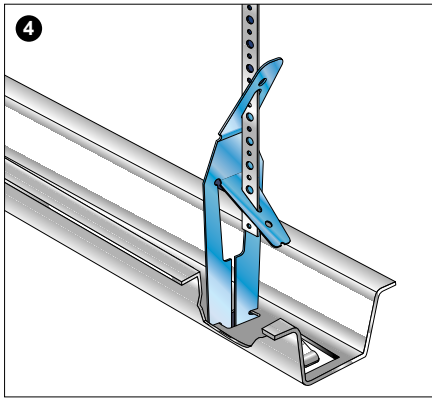

4 Adjustment Clip No. 5 is located into the slots provided in the modular carrier. Minimum suspension height is 170 mm. The pull-out force of the hanger must be at least 2.5 times the hanger load.

5 Modular Carrier No. 40 is provided with pre-punched lugs and cut-outs for modular splicing. Locate the carrier ends so that the cut-outs overlap and lock together by folding the lugs inwards.

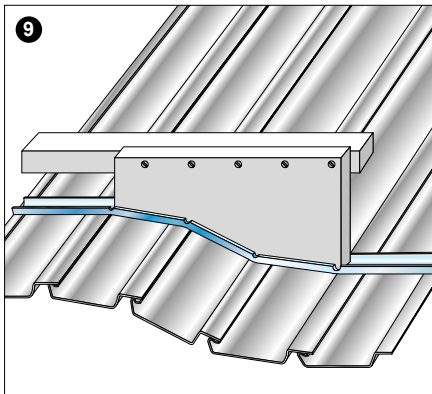
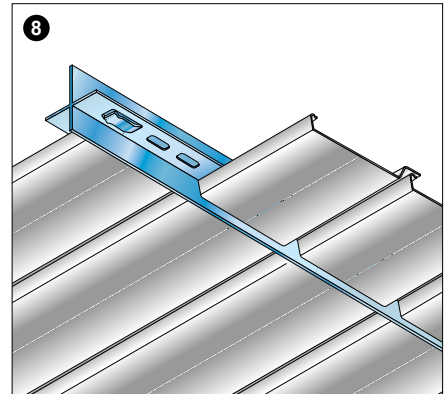

6 Closed joints are formed under Modular Carrier No. 43 (double carrier). Hangers must be fastened alternatively to both sides of the carrier to prevent twisting. Only the DAMPA 10 ceiling, using a splice inlay, can be butt jointed without end closings. Locate the splice inlay in the unit and hold in position while securing to carrier. Install second unit to complete closed joint. The splice inlay must not be pushed into the units after installation.

7 Featured joints are formed under Modular Carrier No. 43 (can be supplied painted). The maximum width of the open joint is 50 mm.

9 Concave or convex curved surfaces to a minimum radius of 500 mm can be achieved using Modular Carrier No. 44. The carrier is fastened at 300 mm centres to pre-shaped timber or metal profiles spaced at 1350 mm centres maximum.

10 The two types of linear ceilings are both in 100 mm module and are clipped on Modular Carrier No. 40. The DAMPA 10 ceiling system is a stand-alone system with sides of the profile sloping outwards. The DAMPA 100 ceiling system, with right angle sides, can be integrated into a solution with DAMPA 200 and DAMPA 300 as part of a design combination or as adjustment profiles.

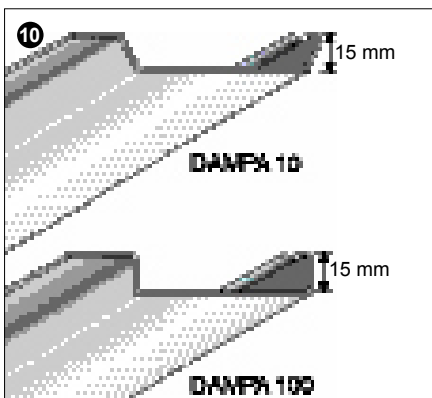

8 Jointing details are formed by engaging the units into the clips of the pluschannel. The supporting hangers must be fastened alternatively to both sides of the pluschannel to prevent twisting. The distance between pluschannels and modular carriers or two pluschannels must not exceed 1000 mm.

Dismantling

It is possible to remove and reinstate individual ceiling units without the use of tools. To remove, pull the unit towards you horizontally and simultaneously push the nearest adjacent one.

